

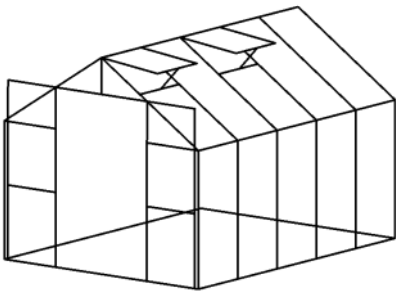

Titan 912 /914 EB
Greenhouse
Assembly Instructions
v2023



Model Titan 912 EB

Please note. Vents can be put closer to the plain gable end instead of at the door end. Just not side by side.

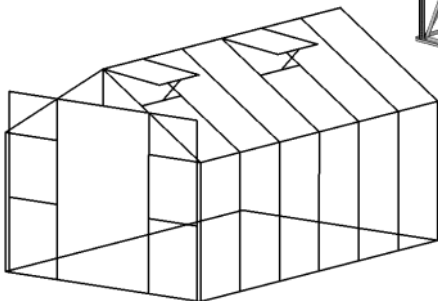

Model Titan 914 EB

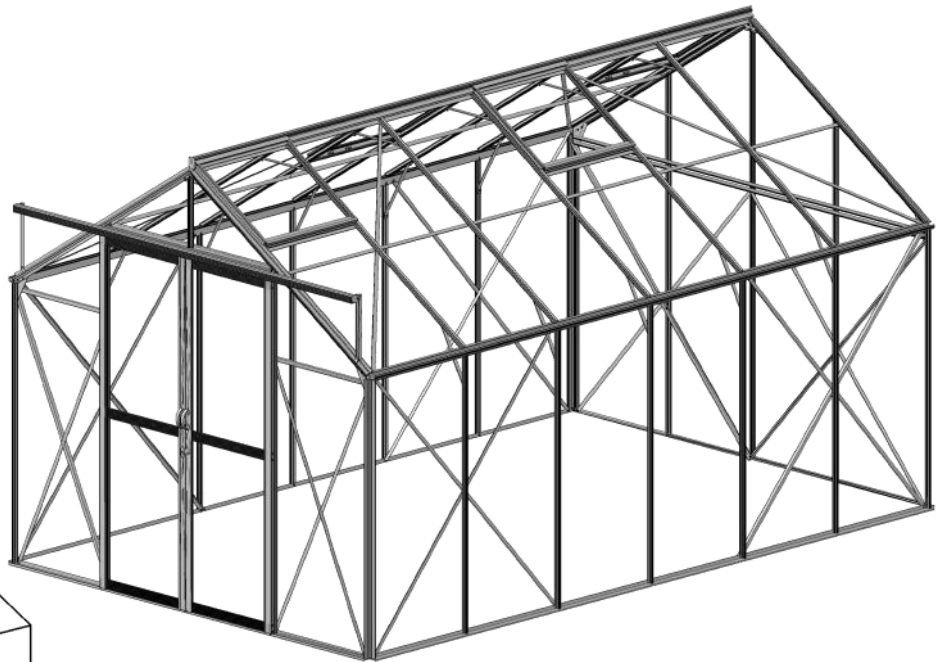

Hunkin Garden Products Ltd
sales@hunkin.co.nz www.hunkin.co.nz
Ph 0800 14 48 65
09 236 9390

Dear Customer!

Thank you for purchasing one of our greenhouses. We feel sure that by following the detailed assembly instructions, you will find as much pleasure in constructing the greenhouse as you will enjoy growing plants in it. The assembly instructions are a combination of text and illustrations and some very limited technical knowledge is required for the erection of the greenhouse. The frames are numbered and packed separately corresponding to the pages in the assembly instructions.

Assemble one section at a time. Bolts and various fittings for each section are included with each pack. Each pack has a specified list of components.

We have attempted to make the greenhouse as strong as practicable, but it still requires protection from strong winds. The best shelter is a semi permeable one where the wind is filtered (50% is the optimum) but not completely stopped. Beware of situating your greenhouse between solid objects as it funnels the wind. As an analogy. Think of how fast water runs through a narrow part of a stream compared to the wider part. A sheltered greenhouse will be much more efficient at retaining heat, which is what we are trying to achieve.

Guarantee

There is a 10 year guarantee that covers replacement or repairs of defective frame parts due to material or a manufacturing fault. The guarantee is limited to replacement of the faulty parts and does not cover assembly costs, post and packaging or freight etc. The polycarbonate has an 8 year guarantee against going brittle. The guarantee is invalid if the greenhouse is not assembled according to these instructions and if the polycarbonate has not been assembled with the UV side facing the sun. The guarantee does not cover wind, snow and storm damage or other natural disasters.

Winter Protection

Our greenhouses are constructed with frame dimensions up to 50% stronger than some competing products. We still recommend you protect your greenhouse during the winter if you are expecting heavy snow or high winds.

- Support the roof ridge at the centre of the greenhouse if expecting heavy snow.
- Don't let snow build up on the roof.
- Site your greenhouse so snow can't fall from trees or nearby roofs onto your greenhouse.
- Lock the door and windows to prevent wind damaging the greenhouse.

Foundation

The base is included with the greenhouse. All bases are powder coated to protect them from ground salt corrosion. The base is maintenance free and, of course, all the fittings are included. Remember to order concrete as this is not included in the kitset. Premixed bags of standard concrete or rapid set (just add water) are available at your local hardware store. **A secure base is key!**

Maintenance

- Grease doors, hinges and door track.
- Clean the gutter for leaves etc.
- Check adjustment of windows.
- Replace any damaged polycarbonate.
- Wash the polycarbonate with a warm soapy solution. Do not use solvents.
- Clean the greenhouse with disinfectant before and after the growing season.

We endeavour to supply a quality product, however should you encounter a problem please contact Hunkin Garden Products Ltd either by email sales@hunkin.co.nz or by free phone 0800 14 48 65. To help us identify the problem please refer to the assembly instructions and the list of components.

Caution



Peel back approximately 2 inches (50mm) of film from both sides before installing. Remove all film immediately after the construction is completed. Mark the sheets with a permanent felt tip pen to indicate the correct side to the sun.

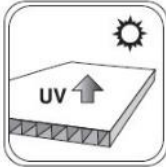

The UV-protected side of the sheet has printing on the film and must face towards the sun. The side with the clear film goes to the inside. Remove all film.



Please put on gloves to avoid cutting your hands.



Treat the polycarbonate carefully so it is not bent or damaged.

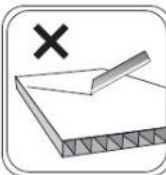

Keep the polycarbonate away from material that could scratch it. Don't put the edges on the ground.

Important

- The base must be fastened to the ground using concrete around the pegs.
- The greenhouse must be securely fastened to the base.
- The base must be 100% level and square. The easiest way to ensure that the base is square is to measure across the diagonals. The diagonals should measure the same.
- We recommend greasing self tapping screws for easier assembly.
- Glazing should only be carried out in fairly calm weather.
- Make sure that the greenhouse is square before starting to glaze.
- We recommend using gloves while glazing.
- An assistant will make the job much easier.

Tools

The greenhouse is assembled by means of the following tools:

- Spirit level
- Spanner/socket spanner 8 and 10 mm
- Screw driver (a battery drill with a clutch is very handy for quicker assembly)
- Caulking gun

Base

The base is powder coated green. This protects the base from ground salts and makes it far more durable when in ground contact.

The bolt heads slide into the base channels. Leave the concreting of the middle pegs until later. Some need to line up with the greenhouse frame and it is much easier to align and concrete them later.

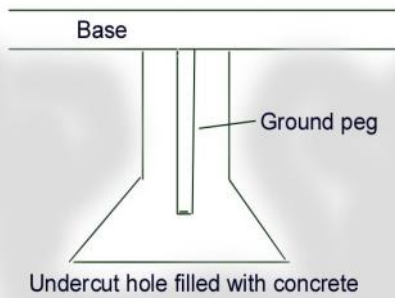

Dig a hole a minimum depth of 300mm or until you reach hard clay and give it some undercut before concreting the base pegs in. The pegs must be concreted into hard ground, not loose fill.



Tip: Leave the concreting of the middle pegs until you have attached the frame. This way you can line them up perfectly with the uprights

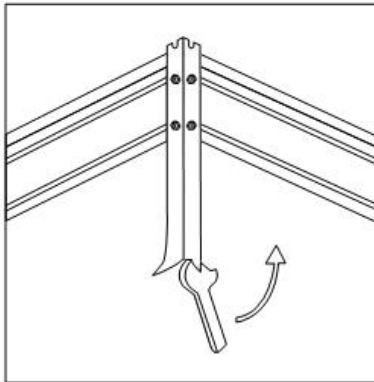
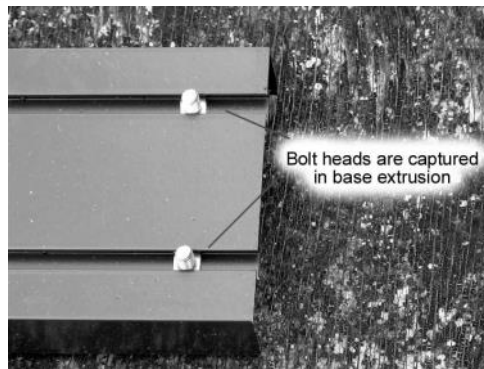

Assemble the base on the ground and square it up by measuring across the diagonals. Mark the position of the ground pegs on the ground and remove the base. Dig 300mm deep holes at the marked peg positions with a spade. You will have to go deeper if the ground is not solid. Some undercut in the bottom of the hole is recommended. Put the base back over the holes. Once level and square fill the holes with concrete and leave undisturbed for at least 3 days, longer if the temperature is below 20 degrees.

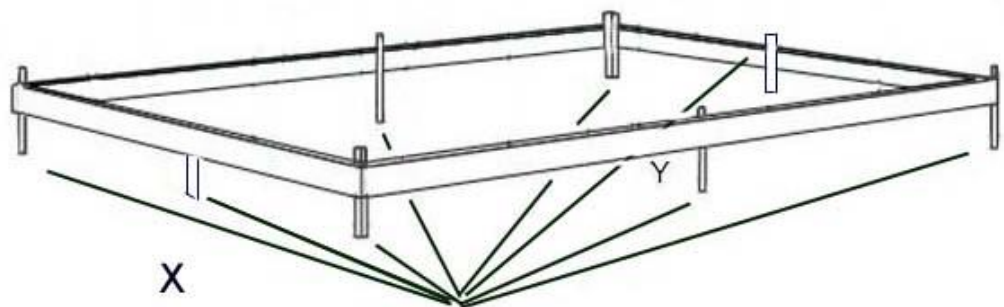

Concrete in all the ground pegs.

	X	Y
Titan 912	2723mm	3553mm
Titan 914	2723mm	4247mm

	X	Y
Titan 912	8'11"	11'8"
Titan 914	8'11"	13'11"

Front gable (view from inside looking out)

Package No.1

1															
#	611	621	641	651	652	663	664	662	711	712	723	a1	a2	m1	m2
mm	2664	1249	1535	1571	1571	2009	2009	381	1634	710	1623	M6x10	M6	-	-
QTY	1	1	2	1	1	2		1	2	2	2	28	28	1	2

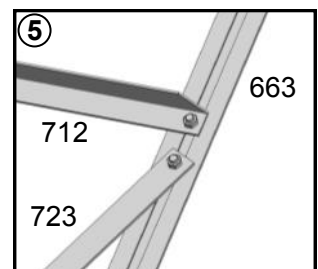
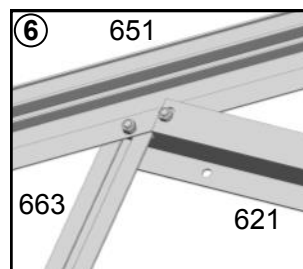
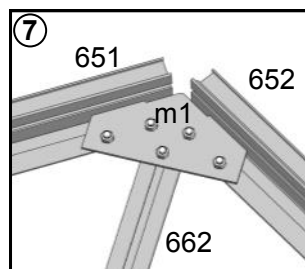
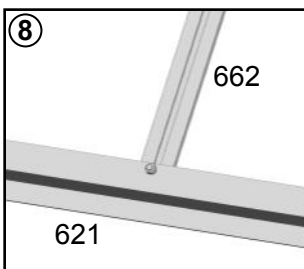
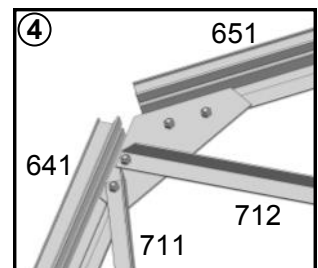
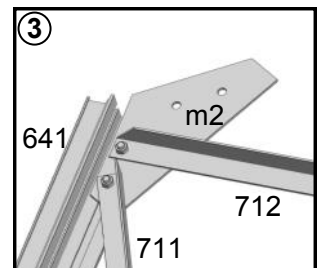
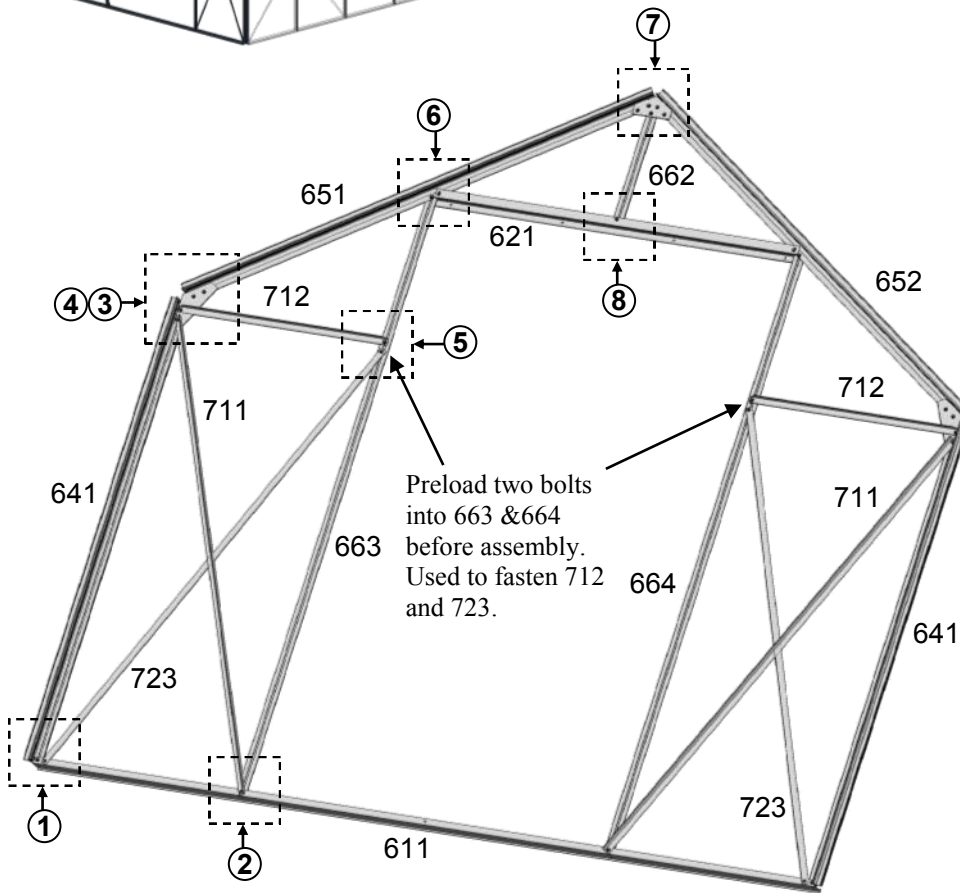
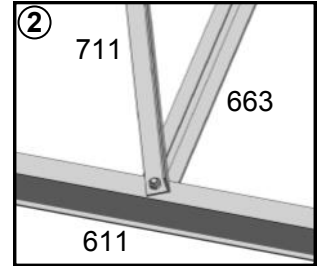
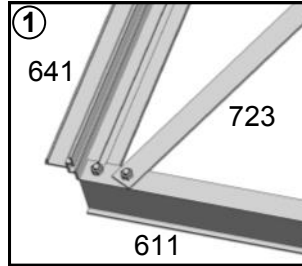
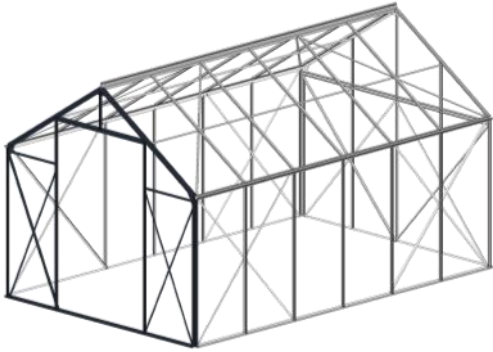

5

Rear gable (view from inside looking out)

Package No.2

2															
#	631	641	653	654	663	664	665	781	721	726	a1	a2	a3	m1	m2
mm	2664	1535	1571	1571	2009	2009	2375	2662	1985	1964	M6x10	M6	M6x15	-	-
QTY	1	2	1	1	1	1	1	2	2	2	27	30	3	1	2

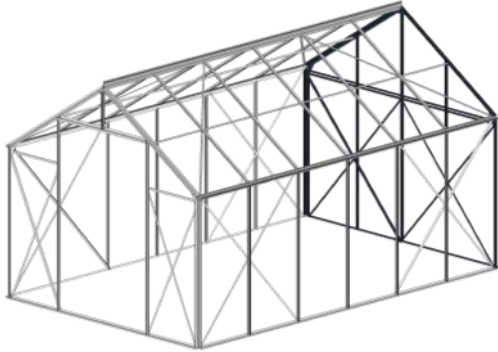

Preload 663, 665 and 664 with two bolts. These are used to fasten 2 x 781 horizontal braces.

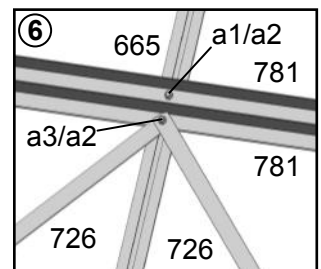
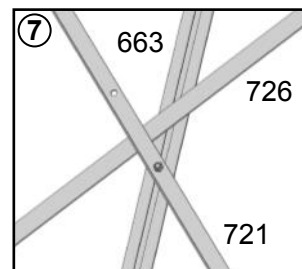
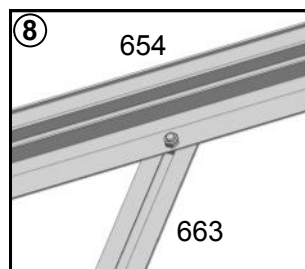
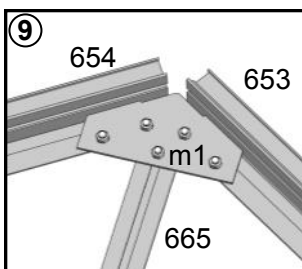
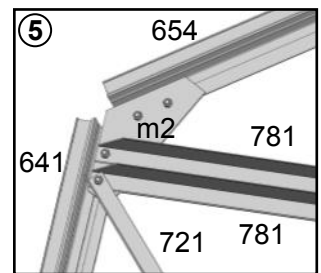
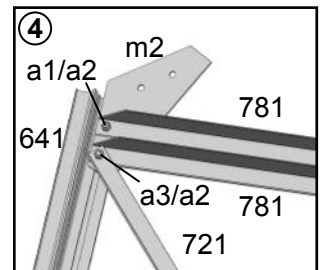
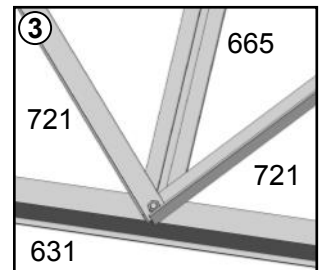
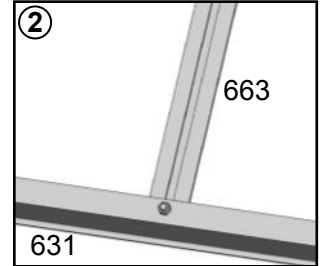
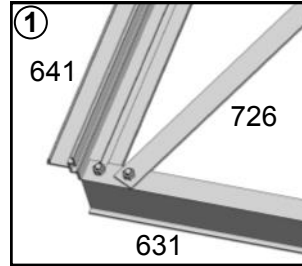
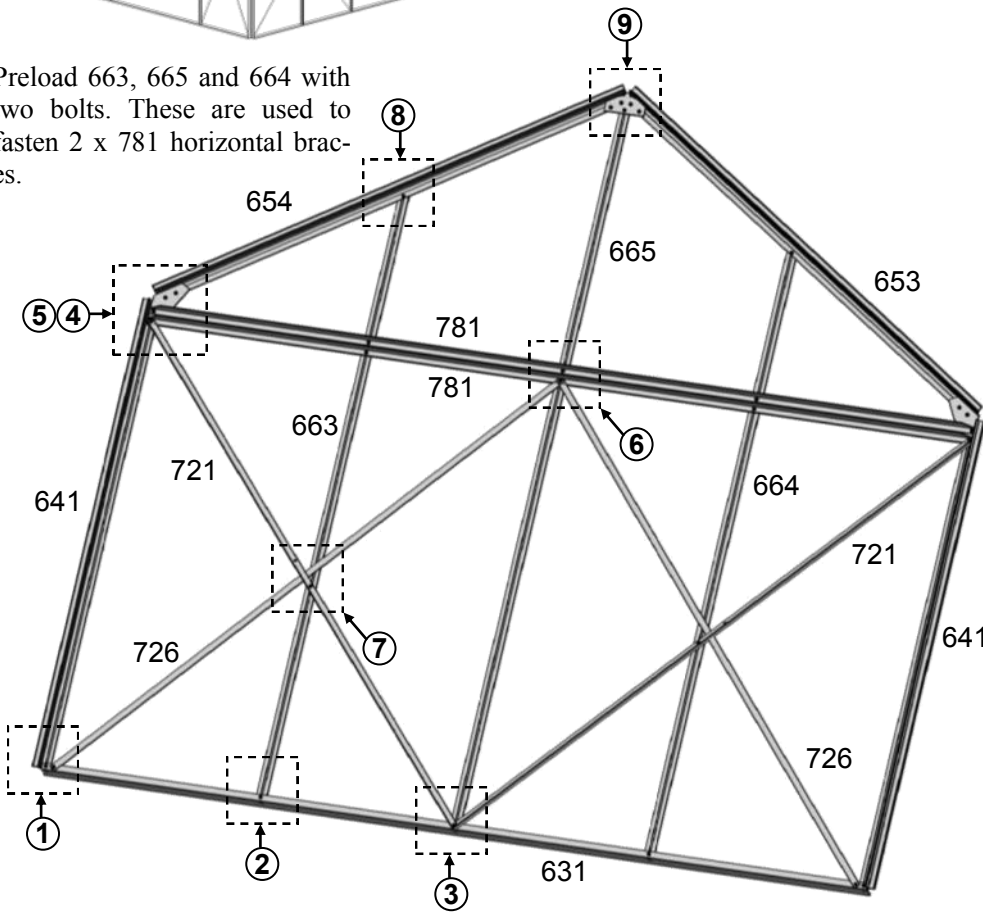

6

Side wall

Package No.3

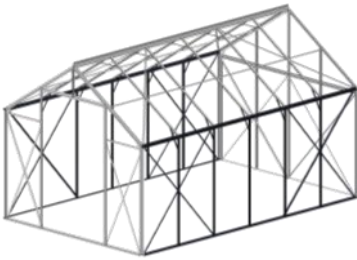

3										
#	5632	6632	666	5671	6671	722	727	753	a1	a2
mm	3496	4190	1535	3496	4190	2055	2055	400	M6x10	M6
Titan 912	2		8	2		4	4	8	56	56
Titan 914		2	10		2	4	4	10	64	64

③④ Preload an extra bolt into 666 before assembly.
Used for eave braces later.

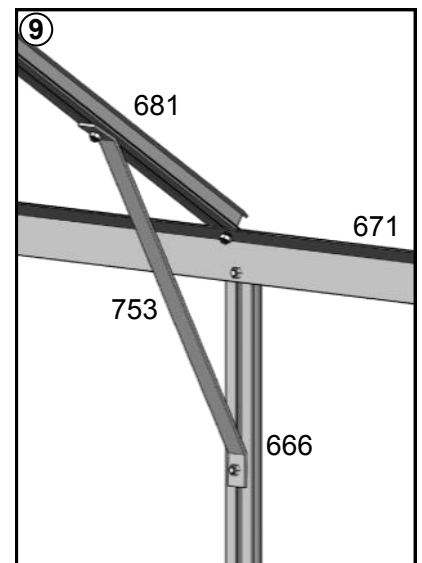
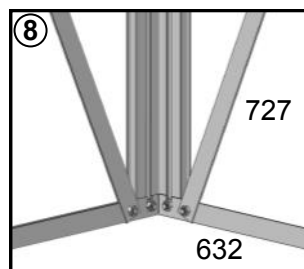
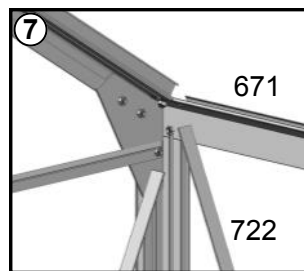
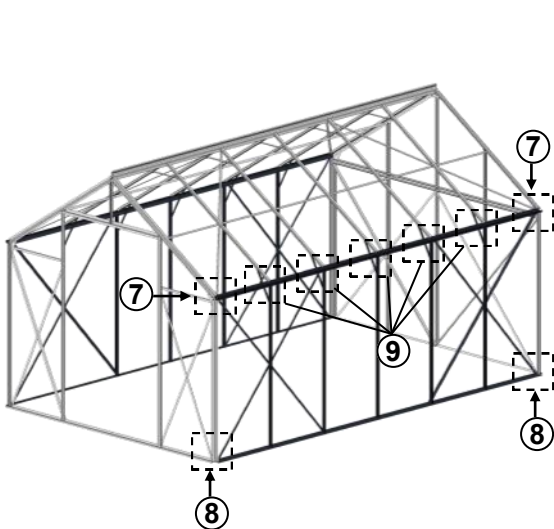
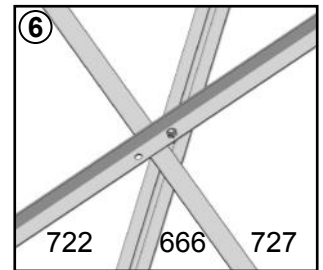
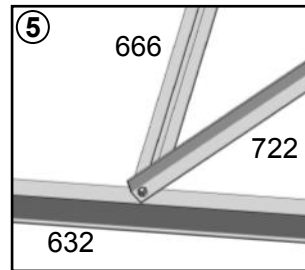
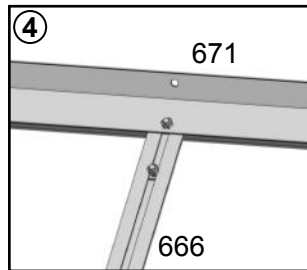
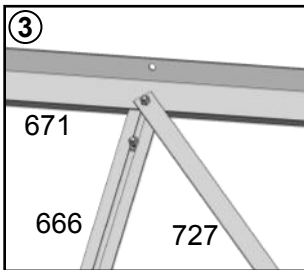
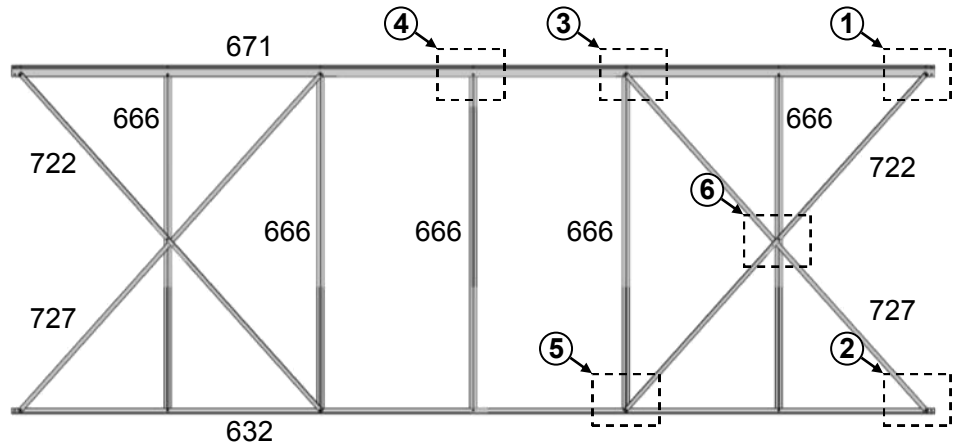
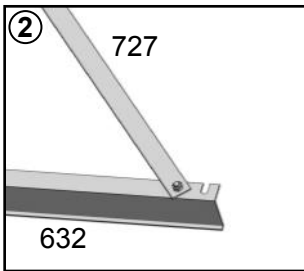
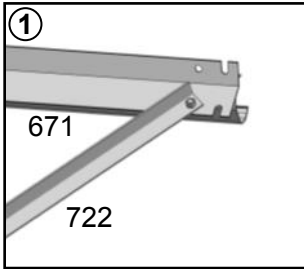

⑦

Roof

Package No.4

All 681 profiles should be preloaded with 4 bolts ie: all 681 profiles should have 4 free bolts once the eave and ridge have been attached. When fitting 713, the full length brace, leave one bolt free in 681 below 713 and two free above it. These bolts will be used to connect apex, eave and 713 brace. Vent parts 521 also need these bolts.

4										
#	5701	6701	681	5713	6713	752	751	a1	a2	B-p1
mm	3496	4190	1571	3485	4179	2082	400	M6x10	M6	-
Titan 912	1		8	2		4	4	44	44	2
Titan 914		1	10		2	4	5	52	52	2

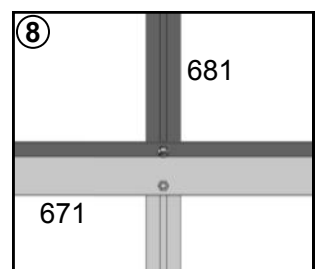
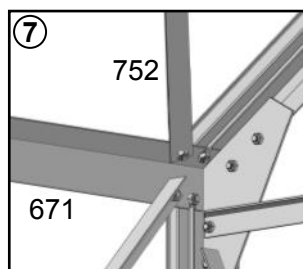
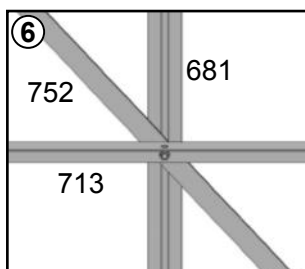
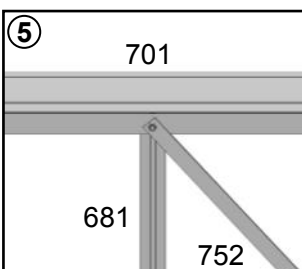
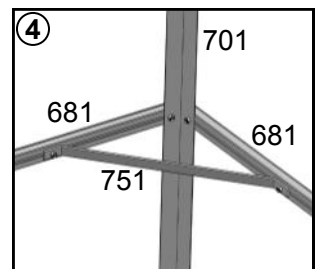
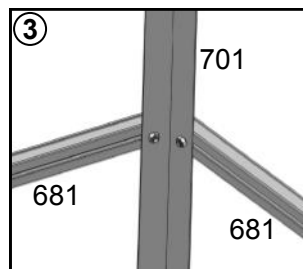
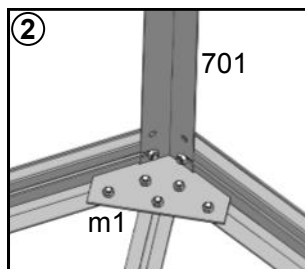
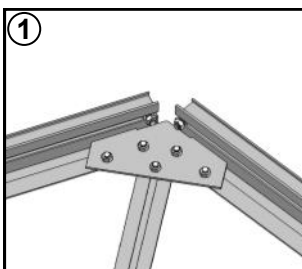
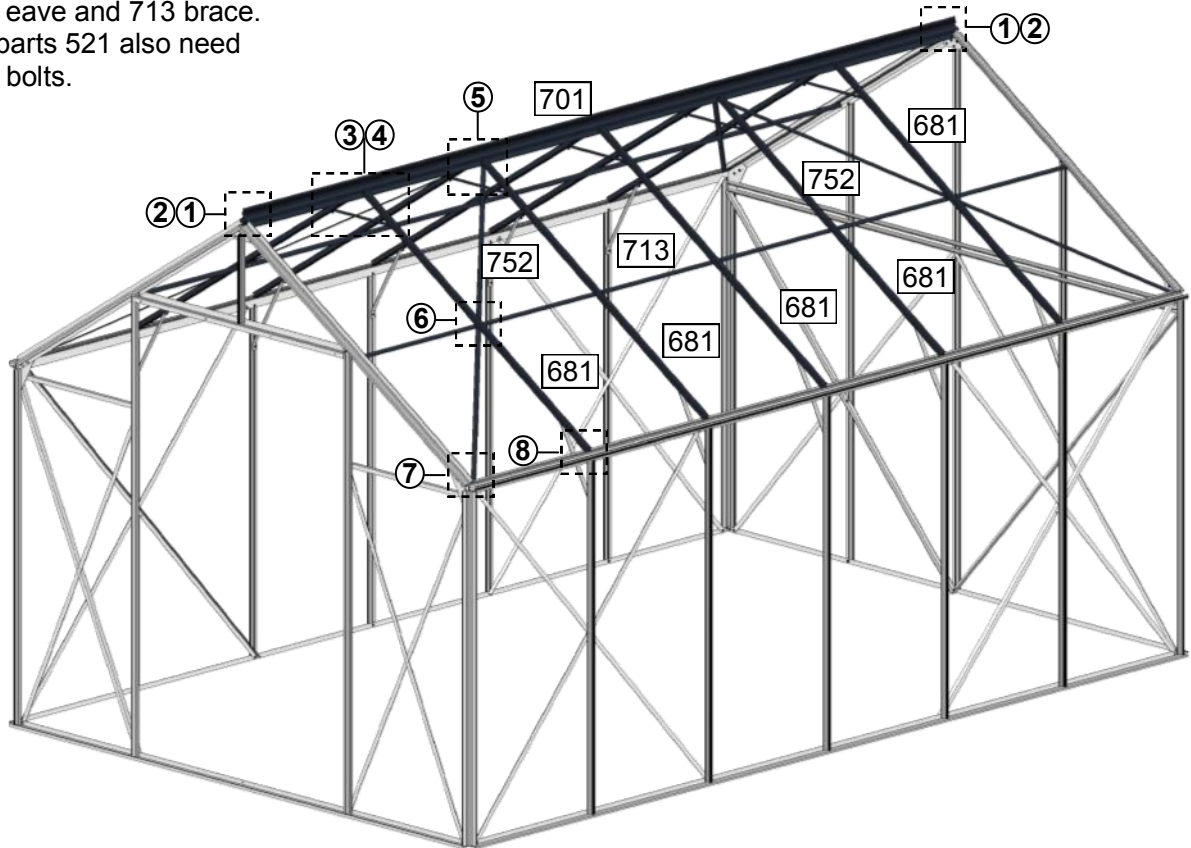

8

Vent

Build the vent around polycarbonate sheet b7. b7 is inserted into the rebated vent frame. No glue required

Package No.6

6												
#	201	521	531	541	551	a1	a2	a7	a9	a4	p3	p10
mm	300	724	601	695	678	M6x10	M6	M4x8	M4	Φ4.2x9.5	-	40
QTY	1	1	2	1	1	8	8	2	2	2	2	1

Vent No.	4
----------	---

Notes on vent assembly

No silicone is used on the vent polycarbonate.

1. Fit either 201 to 551, or if you purchased an autovent follow the alternative instructions using the 4mm bolts & nylock nuts supplied.

2. Fit the vent sides 531 to the vent hinge 541.

3. Slide in b7 (correct side to sun) and attach 551 to the sides 531

4. Repeat the procedure for the other vents.

5. Slide in the vents before you glaze the greenhouse. Fig 4

6. Before you slide in a vent, **slide in one p3/a4**. One of these needs to be positioned on both sides of a vent to stop it sliding sideways. Fig 6, 7

7. When the vent is in position and opens and shuts nip up a4 so p3 remains in position. Do this before you glaze the roof otherwise you will not be able to tighten a4 later.

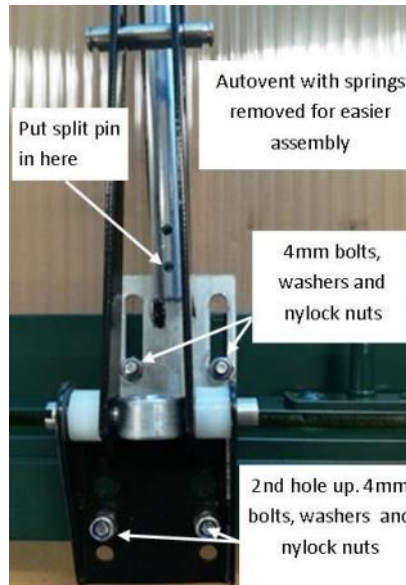
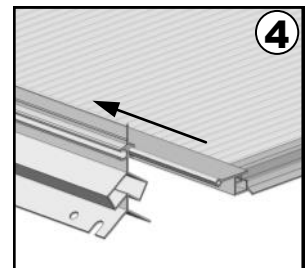
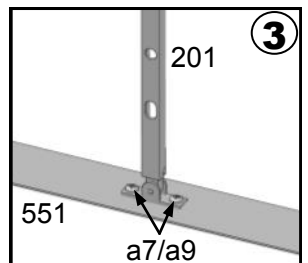
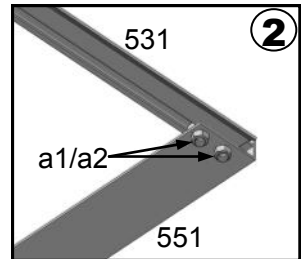
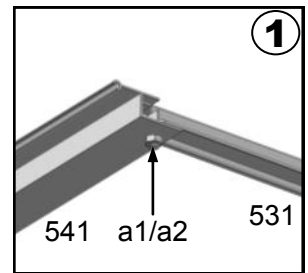
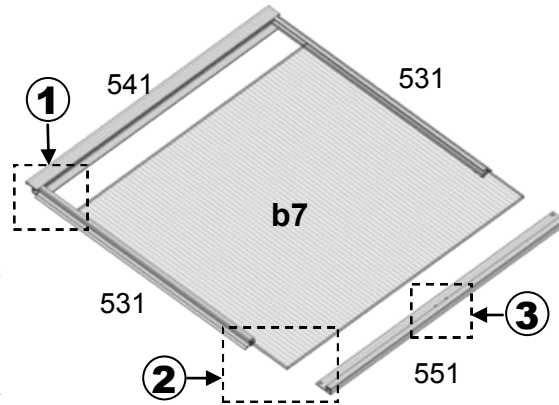

To install the autovent remove the springs and cylinder, then attach the alloy part with the slots to PN551 with 4mm bolts, washers and nylock nuts.

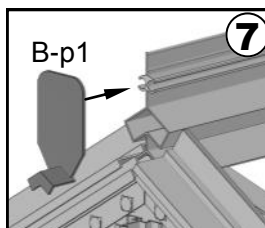
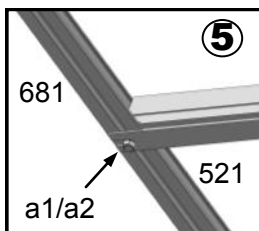
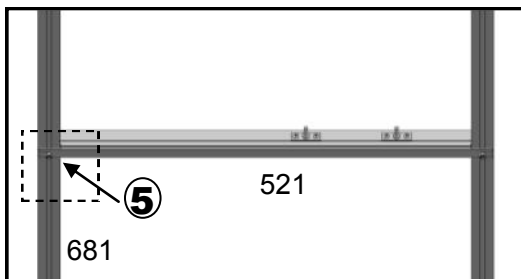

Complete the assembly of the vent installing the B7 polycarbonate (top centre picture). Slide the vent into the ridge and position it #6 below. Attach the bottom section of the autovent using the 2nd holes to 521. Install 521 in the frame. Attach the springs and screw in the cylinder. A bit of grease on the thread helps here. Line up the cylinder shaft and arm holes and insert the split pin in the position as shown above.

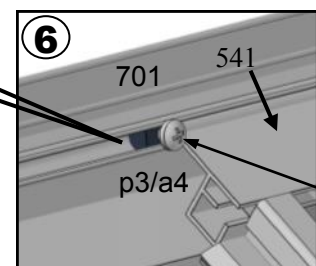
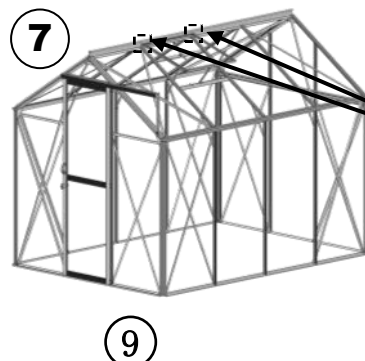

Door

Tip: Grease the self-tapping screws before you screw them in
No silicone glue is required on the doors.

Package No.5

5													
#	572	581	582	583	591	592	593	791	595	384	p4	p5	m10
Size	2530	623	633	633	1942	1942	1942	359	890	-	-	-	-
QTY	1	2	2	2	2	1	1	2	8	2	4	2	4

#	n1	a1	a2	a5	a6	a9	a11	p11
Size	-	M6x10	M6	Φ3.5x19	Φ3.5x25	M4	M4x25	1942
QTY	8	16	16	20	8	4	4	1

P4 has slots. When attaching p4 leave it flush with 591 & 593 until you have put the door on the top runner 572. P4 is used to hold the bottom of the door in position (next page).

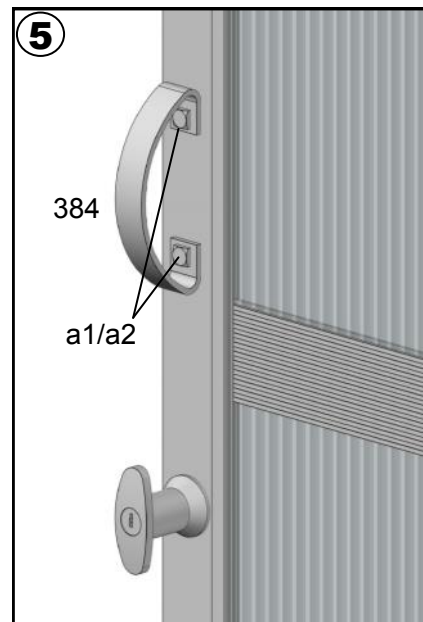
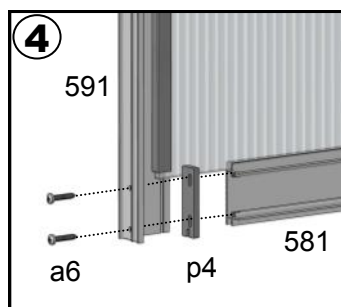
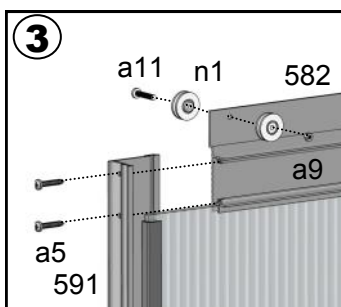
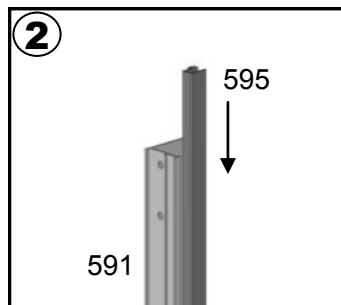
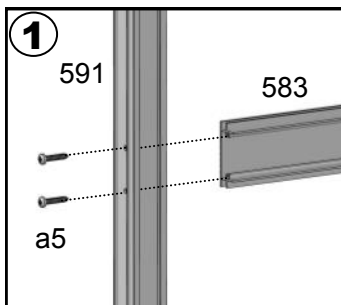
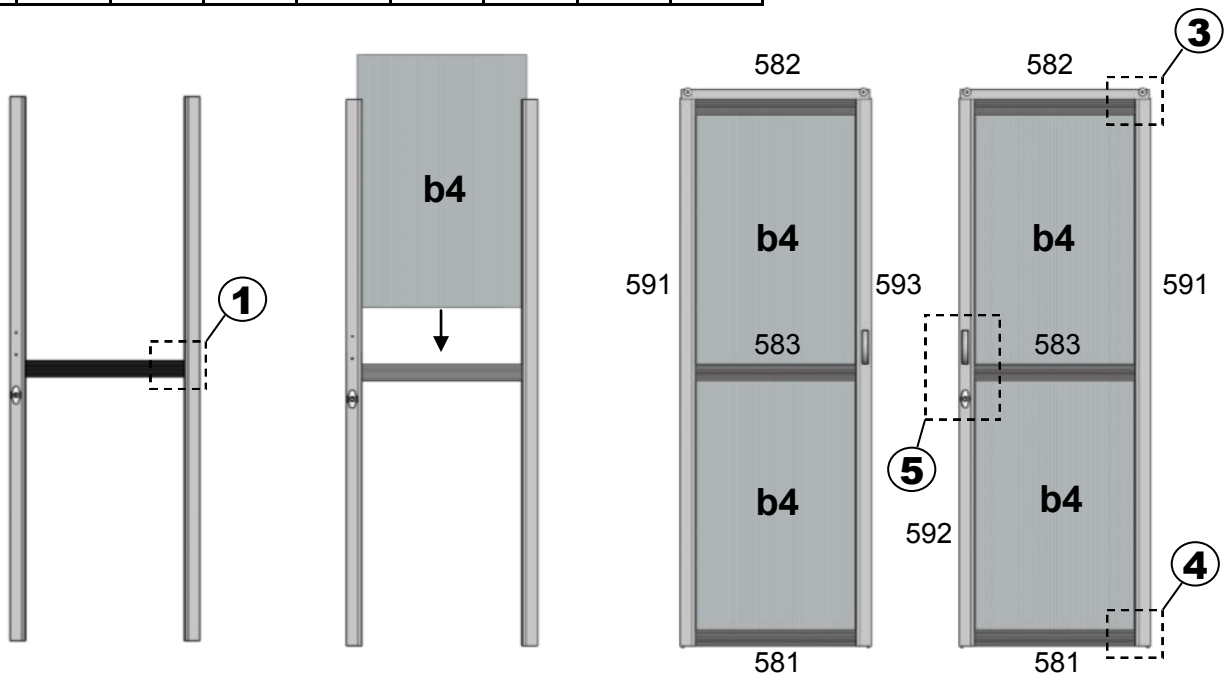

Door

(Tip: Grease the self-tapping screws before you screw them in)

Package No.5

Slide the door rollers into the top rail 572. To get past the frame uprights 661 gently pull the bottom of the door out so it clears them. Having 572 slightly loose helps. Close the doors and slide p4 down until it engages the bottom runner 611. Fig 9

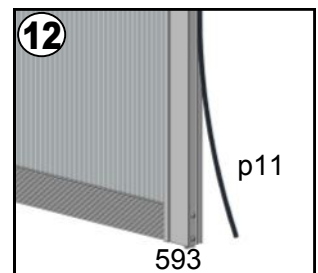
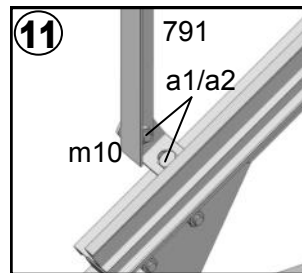
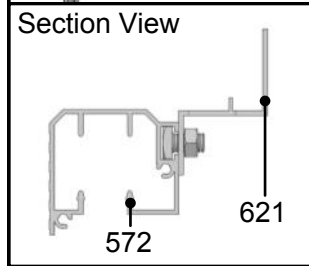
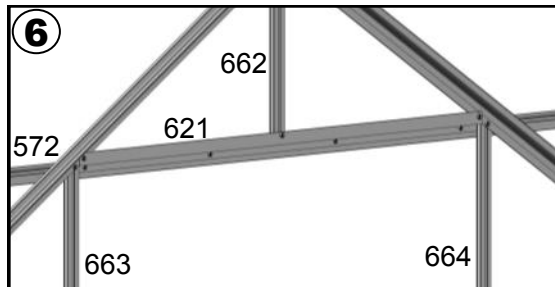
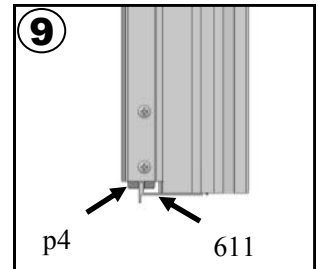
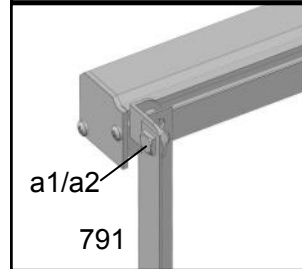
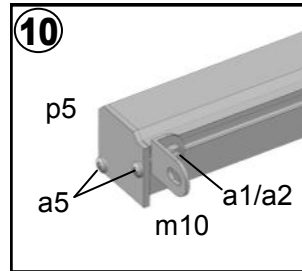
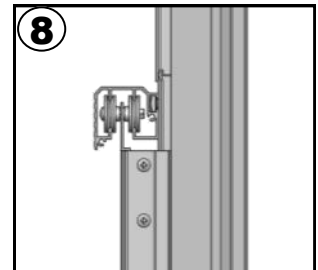
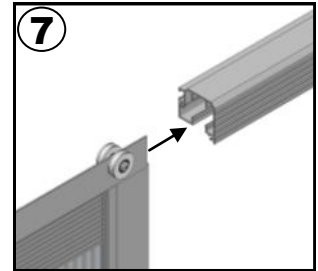
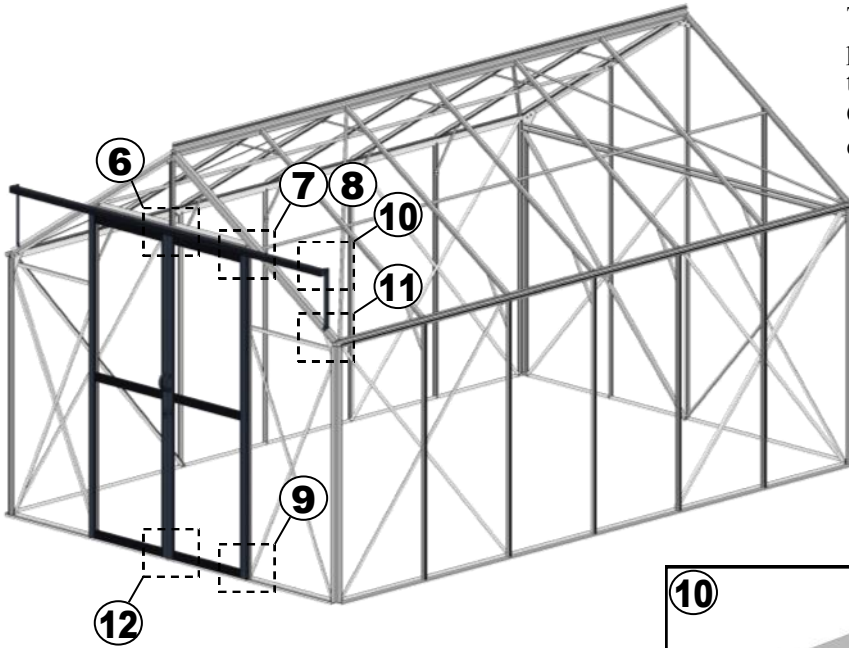

#	P8	P9	P0	P1	P2	m0
mm			Φ36x1000	Φ40	Φ36x200	
	2	2	2	2	2	2

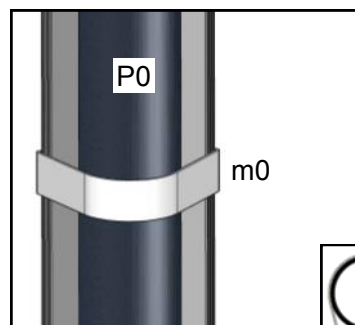
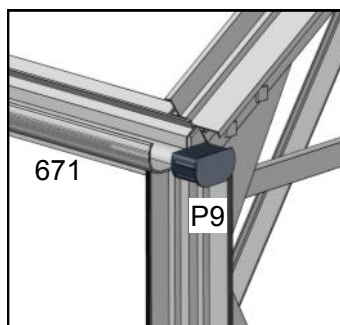
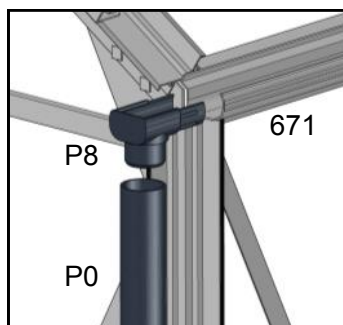

11

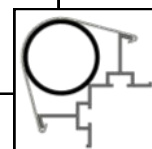

Mounting the frame on the base

The frame, once completed and prior to glazing with polycarbonate, can now be lifted onto the base. Only do this if the concrete has set. With a helper on each corner the greenhouse can be easily lifted into place. Secure the frame immediately (before you have a cuppa) to the base while the helpers hold the greenhouse frame. Once the frame is secured you are free to glaze at any time.

Glazing could take up to a day to complete so choose a day where it is going to be virtually windless and rain free. The silicone glue requires time to set and disturbing the panels during this time can weaken the bond. Try to complete all the glazing in one session, as a partially finished greenhouse is vulnerable to the wind.

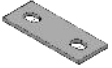
	
#	m7
Titan 912	13
Titan 914	15

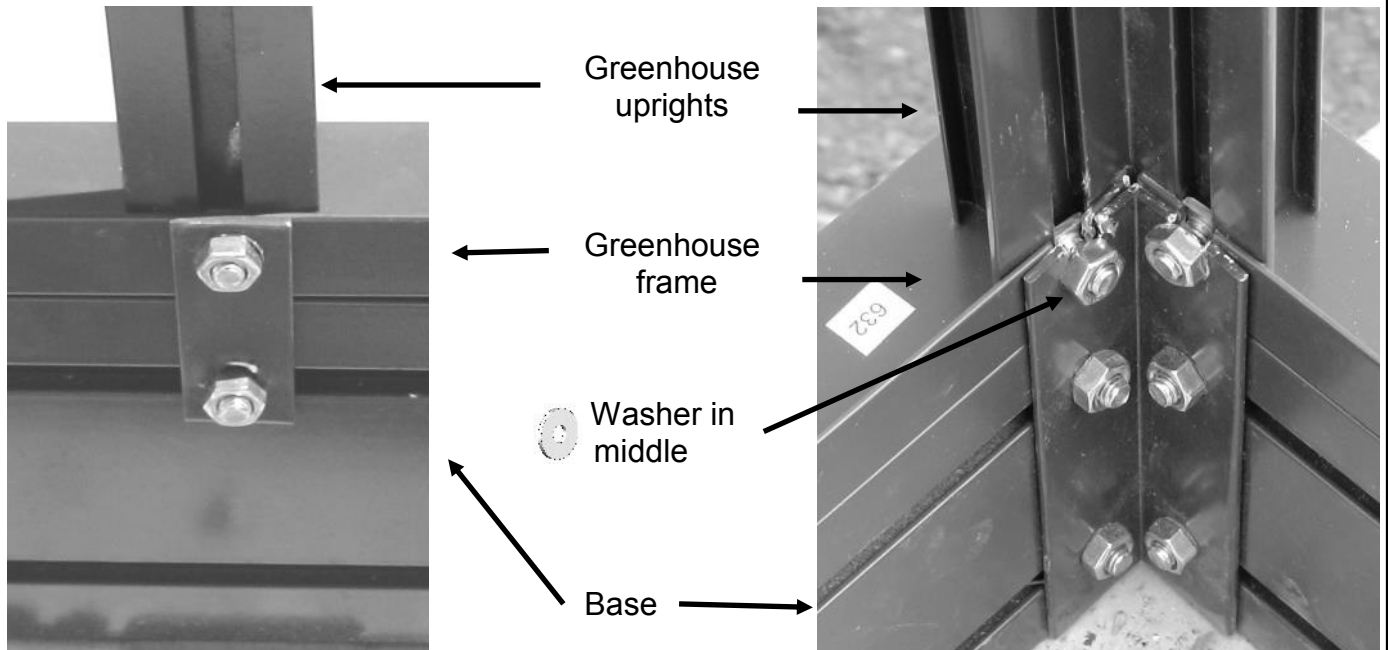
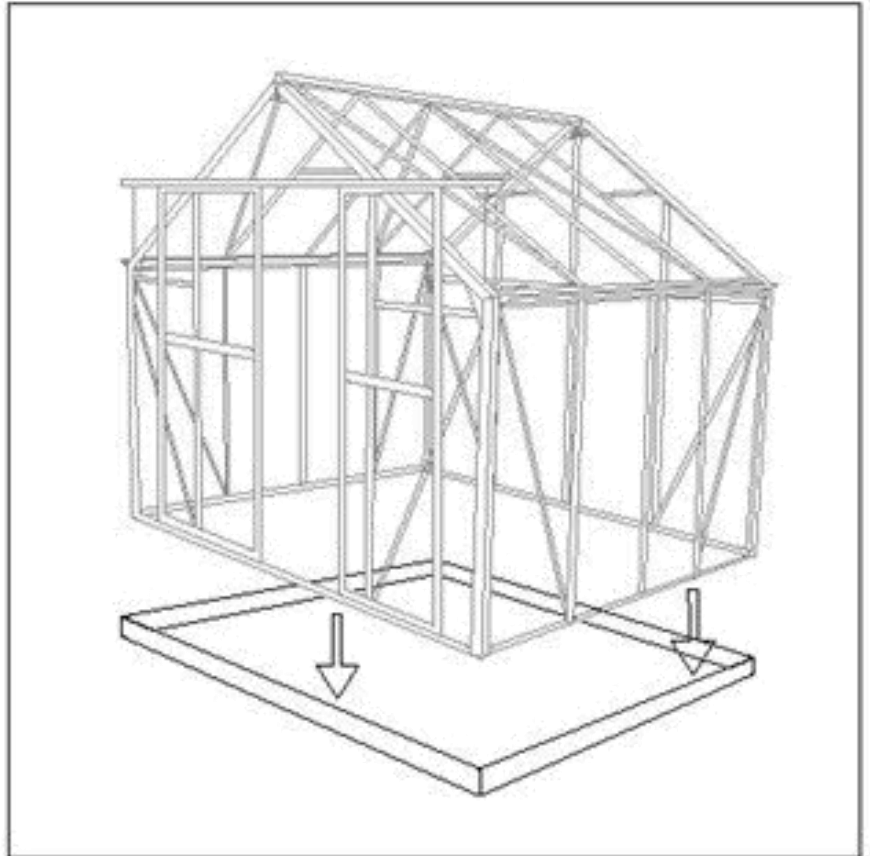

↑
This part is only used if you have made your own base.



Securing the greenhouse frame to the base.

Polycarbonate sheets

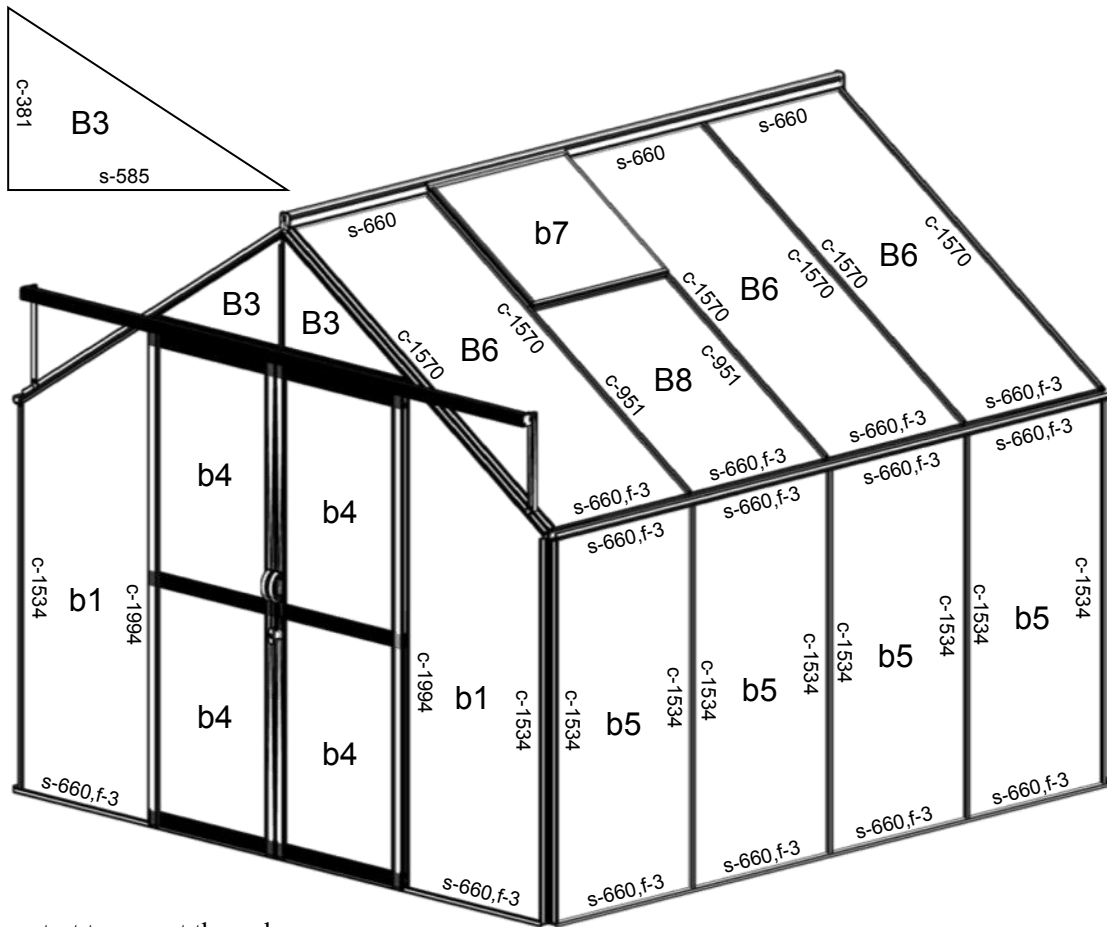
If you are in a high wind area you might like to consider using a MS high performance adhesive sealant instead of the sealer supplied. Avail. Mitre 10, Bunnings etc.



Before you start to mount the polycarbonate make sure the frame is square. All the criss-cross braces should be tight so adjust the frame until they are. It is easiest to fit the polycarbonate to the roof first because you can put a leg of a ladder through the unclad sides for extra stability if required. **Have you fitted the roof vents so they can't slip sideways (page 9)**

Use silicone glue under the areas where the PVC locking strips are going to be placed, ie: under all the vertical long sections. Mark one side of the polycarbonate with a felt tip pen so you know which side is to the sun. Once you take the protective covering off it is impossible to tell. The side that has the printed protective cover sheet goes to the sun.

IF YOU ARE IN A HIGH WIND AREA YOU MAY LIKE TO CONSIDER MS HIGH PERFORMANCE ADHESIVE SEALANTS WHICH ARE STRONGER THAN THE SEALANT SUPPLIED

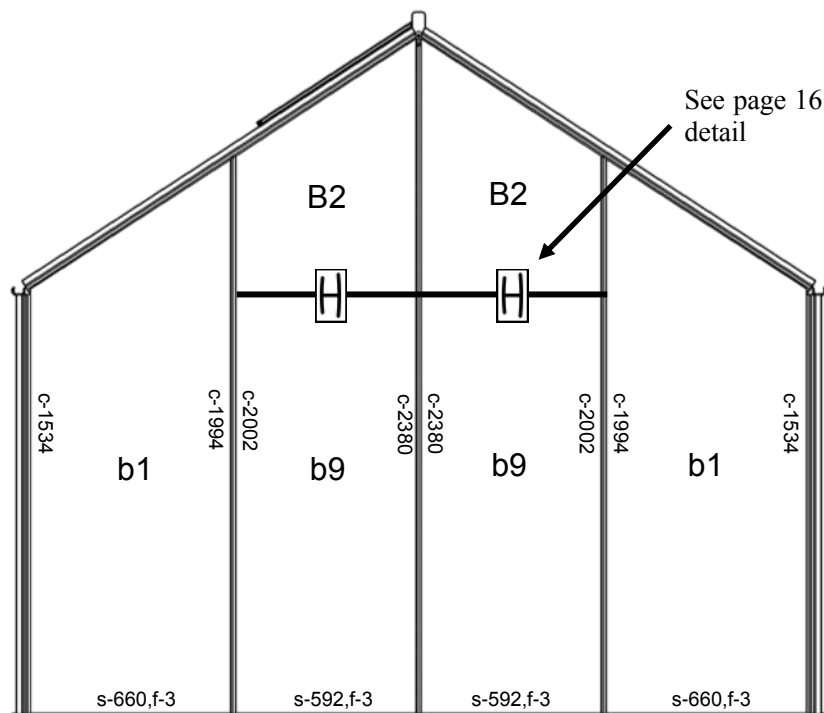

Polycarbonate sheet

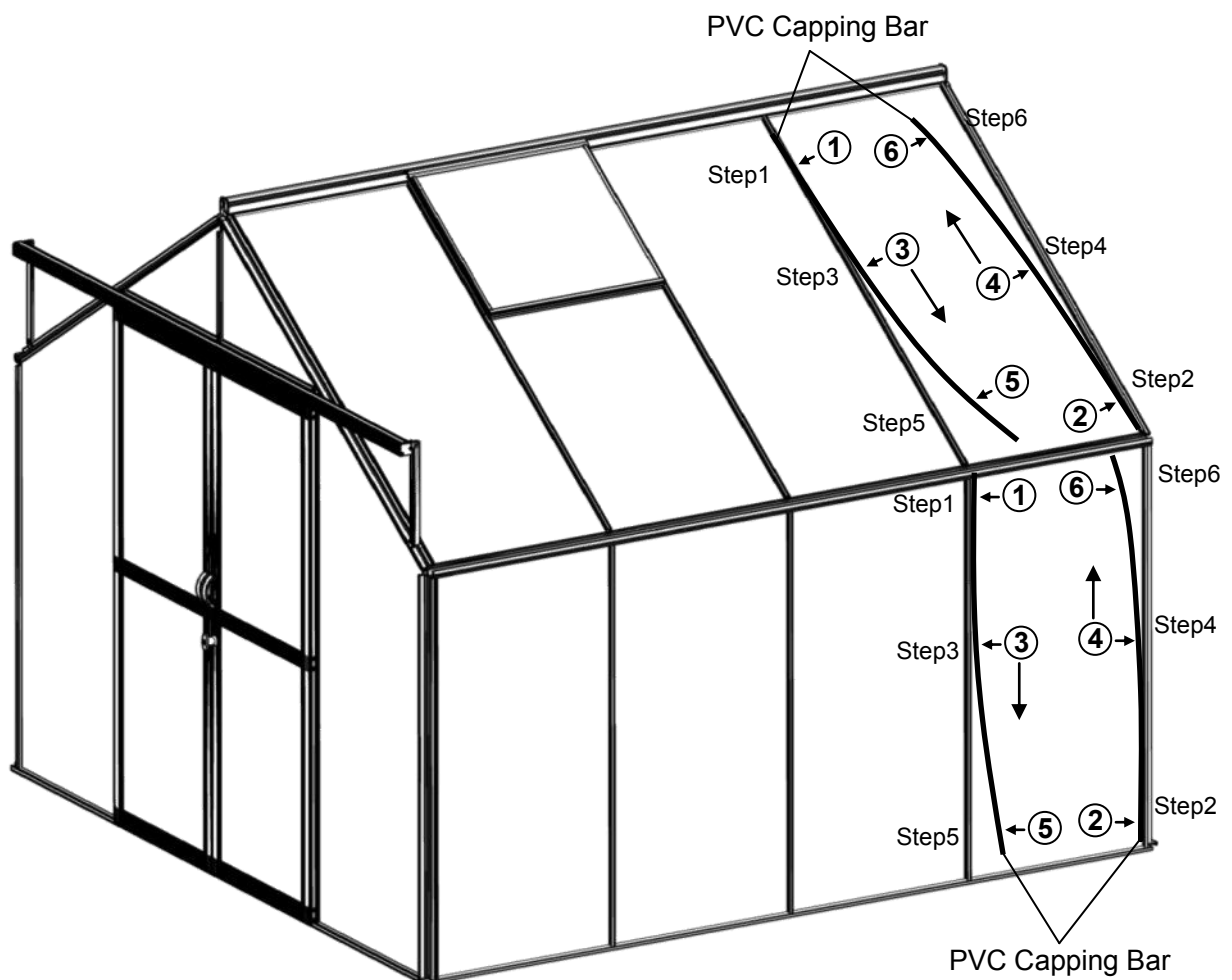

Note:

PVC locking strips are pushed into place from the top and the bottom in a diagonal direction, bit by bit, so the PVC locking strips are fitted evenly. If you fully insert the PVC locking strips from one side only, the polycarbonate panel may move sideways making it very difficult to insert the PVC locking strip to the other side.

Do a trial run before you the sealer on one sheet, so you get the hang of it. This avoids a mess if you have to pull it out again. Page 16 shows you how to insert the pvc locking strips. Easy once you know how.

As mentioned before. If you are in a high wind area you might like to consider using a MS high performance adhesive sealant instead of the sealer supplied. About \$22.00 per tube, but this stuff really sticks. Available from Mitre 10, Bunnings etc.

Installing the polycarbonate sheets (see page 16 for more info)

#	mm	Titan 912	Titan 914
b1	677x1555/1994	4	4
B2	609x476/872	2	2
B3	609x17/413	2	2
b4	572x903	4	4
b5	677x1528	10	12
B6	677x1573	6	8
b7	677x612	4	4
B8	677x956	4	4
b9	609x1528	2	2
H	592	2	2

PVC capping bars (U shaped) are put over the ends of the sheet (top and bottom) to stop moisture and bugs from getting into the twin wall portions of the polycarbonate. Capping bars have the part number "s" and come in various lengths. In some places the shape of the extrusions are designed to cap it for you, so it does not apply in every case. Doors and vents for instance. A capping bar will not fit into an extrusion if it is not meant to, so it is self-evident.

Assemble b1&B2 Panel

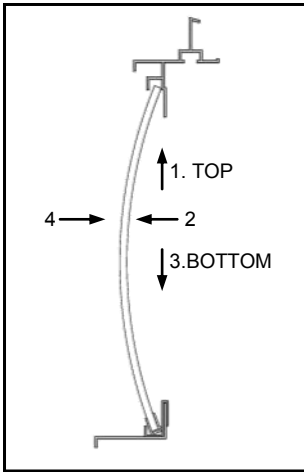

Assemble b5 Panel

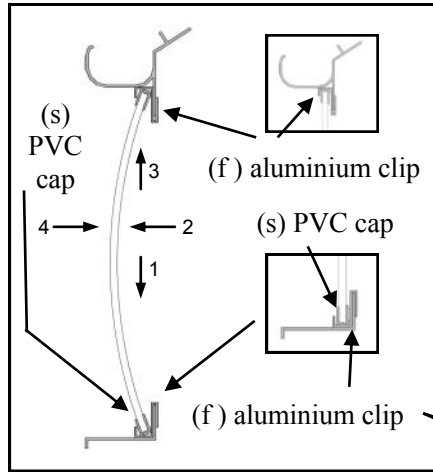

5.SIDE

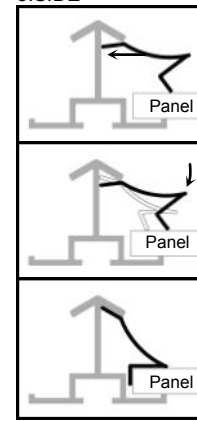

Fitting PVC locking strips

		DWG	Length	Titan 912	Titan 914			DWG	Length	Titan 912	Titan 914		
Front Gable	c		1534	2	2	Rear Gable	c		1534	2	2		
			1994	2	2				1994	2	2		
			381	2	2				2002	2	2		
	s		585	2	2		s		592	2	2		
			660	2	2				660	2	2		
			f		12				6	6	f		12
Roof	c		951	8	8	Side wall	c		1534	20	24		
			1570	12	16				s		660	20	24
			s		660						16	20	f
	f		12	30	36								

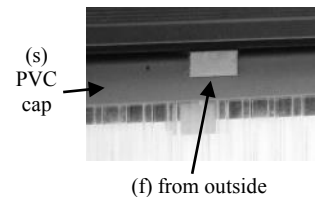
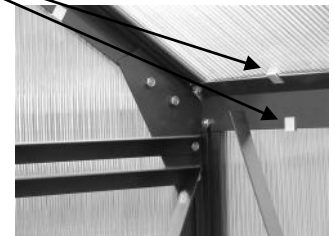

Installing the polycarbonate.

- Only neutral silicone is to be used for mounting polycarbonate. Silicone is used between the frame and polycarbonate on the vertical parts of the roof and walls. The very low weight of polycarbonate requires you to press the sheets firmly into the silicone to ensure a good glue line. The polycarbonate sheets should be secured with the PVC locking strips (c) or spring clips. PVC locking strips have the better wind resistance.
- The polycarbonate is delivered with both ends open. Use the capping bars (s) to seal off the ends.
- The polycarbonate is treated with UV protection and must therefore be positioned with the text / opal side out. Remove the plastic protective film from both sides. Mark one side with a felt pen so you don't get confused.
- If you need more silicone glue use a **neutral cure** silicone. For high wind areas a MS adhesive sealant is the best choice. More expensive than silicone, but it glues as well as seals. Available from Mitre 10 Mega, Bunnings etc.
- Polycarbonate sheets must not come into contact with the ground to prevent ingress of dirt and moisture between the walls. Always rest them on cardboard or similar material during construction.
- Important:** The polycarbonate greenhouse should be protected against strong winds until the silicone has completely set.

Installing the polycarbonate sheet

Inserting PVC locking strips.

W clips and PVC locking strips are supplied with the greenhouse. PVC locking strips are far superior to W clips in the wind so we recommend you use them. W clips have just been left in the kits to be used in case you are short shipped PVC locking strips. They will do the job temporarily until you receive extra PVC locking strips. The strips go in quite easily once you know how. A few pictures are shown below to make this process a little clearer. Run a bead of glue/sealer down the vertical parts of the frame. Twang the polycarbonate (see page 15) in top and bottom by bending it slightly and then push it against the frame. Secure with the PVC locking strips.



Please note. The doors and vents have polycarbonate inserted into them as they are built. With the rest of the greenhouse polycarbonate is put in after the frame is built.

Assemble B3 Panel

